

MORE OPTIONS – THE MULTI-WAY DISTRIBUTOR FOR OPTIMAL TRANSPORT

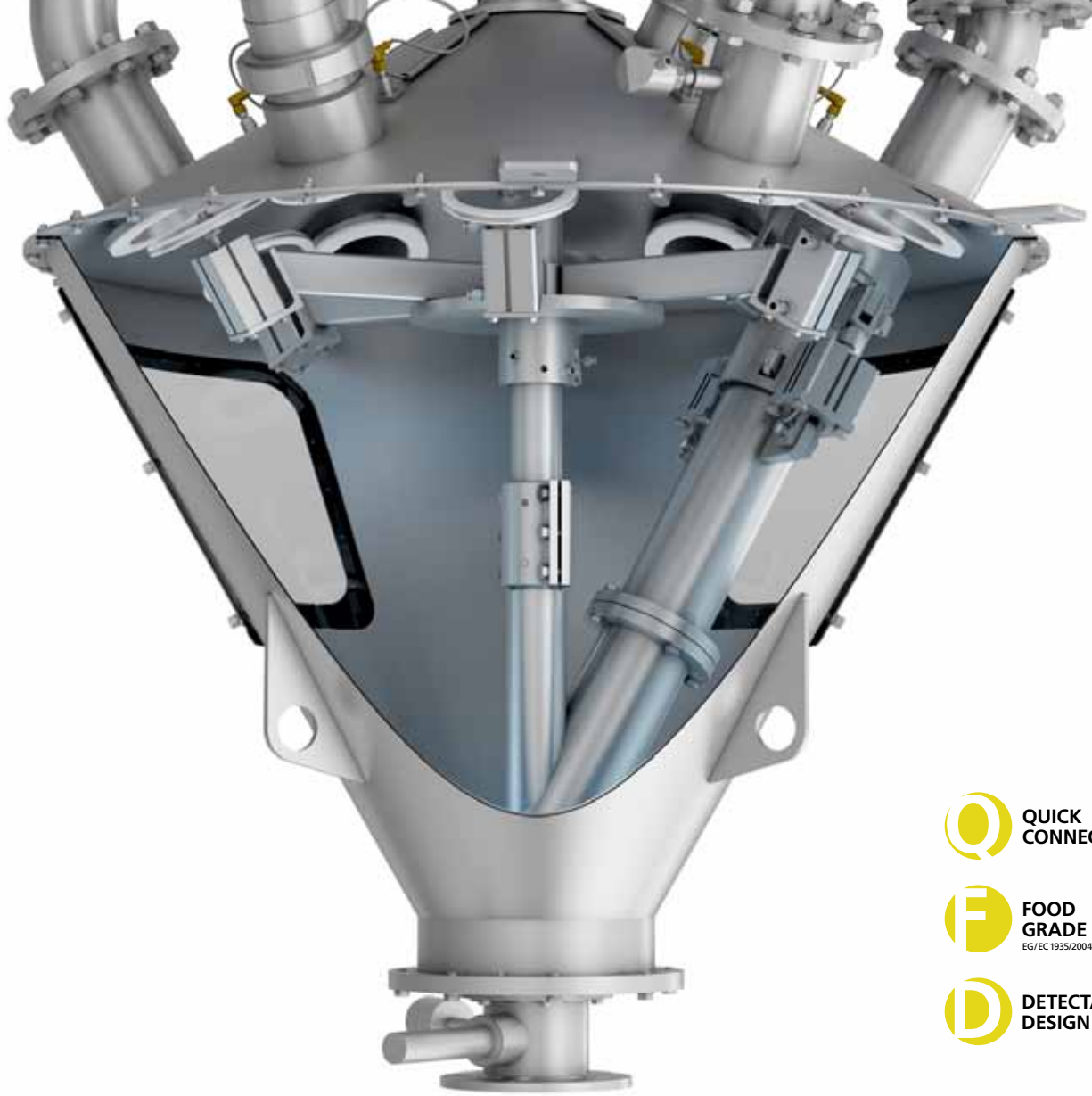



**QUICK
CONNECT**



**FOOD
GRADE**
EG/EC 1935/2004 plus FDA



**DETECTABLE
DESIGN**

When it comes to handling foods, care is key.

JACOB's FOOD GRADE range sets new benchmarks to optimise your production processes. For example, with its multi-way distributor designed specifically for hygiene-sensitive products, such as powdered milk.

As a result, each of its components coming into contact with the product complies with FDA regulations as well as EC 1935/2004, reliably transporting your product to its destination. The system features an extremely high degree of flexibility and can be customised to suit your exact needs. A wide variety of measurement and sensor options are also available for integration.

Performance options

- In accordance with EC 1935/2004 and FDA
- Pneumatic conveying up to 3 bar possible
- Linished, passivated or electro-polished surfaces (surface roughness < 0.8 µm)
- ATEX version
- Integration of measurement and sensor systems as required (pressure sensor, temperature sensor, filling level indicator, flow meter, rotary encoder, pressing control/position control, safety sensor, inspection flap, moisture sensor)
- Backlog shut-off devices (e.g. pinch valve, ball valve)
- Joint connections (e.g. hygienic coupling, Triclamp)
- Interior monitoring with camera
- Control with bus system

JACOB SÖHNE GMBH & CO. KG

Niedernfeldweg 14
32457 Porta Westfalica · Germany
T +49 571 9558-0
F +49 571 9558-160
post@jacob-rohre.de
www.jacob-rohre.de

JACOB

NO. 1 IN PIPEWORK SYSTEMS