

In Line fan type BIL

BIL is a direct driven duct fan with aerodynamically profiled guide vanes. Some of the benefits BIL offers you.

- Space saving installation.
- Efficiency up to 90% and low sound level.
- No risk of bad duct connections.
- Ideal venturi combined with a hightech non overload airfoil impeller.
- Different options of materials and types of motors.
- Price competitive installation.

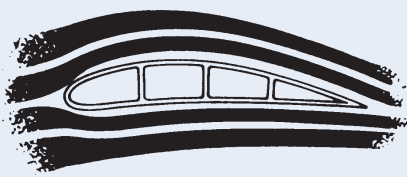
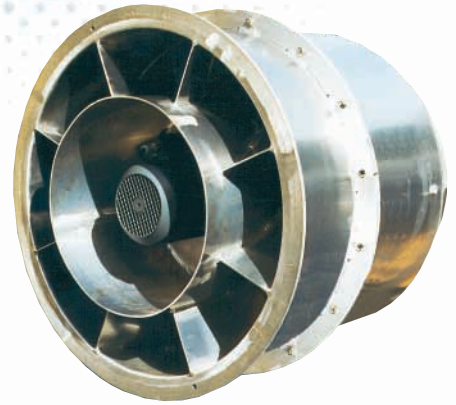

The airfoil blade.

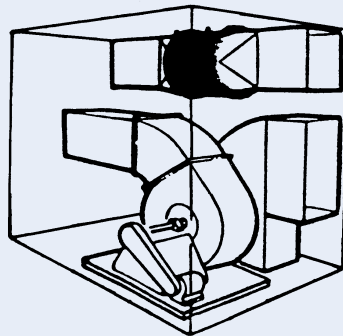

Silent and spacesaving.

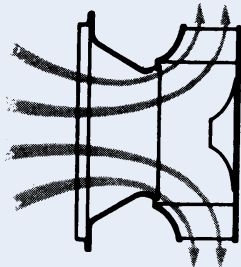

Ideal aerodynamic combination Venturi-Impeller

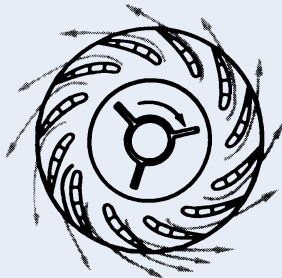

Stable airstream no turbulence.

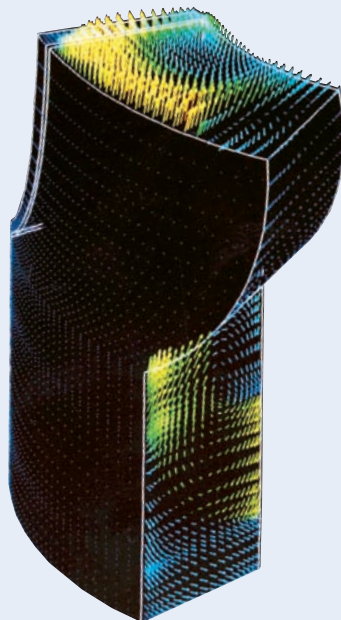

Speed profile through the fan.



Roof units for exhaust and inlet air, non ducted arrangements are some of the applications using BIL.



Roof unit swingout model.

Dimensions for BIL Inline fan

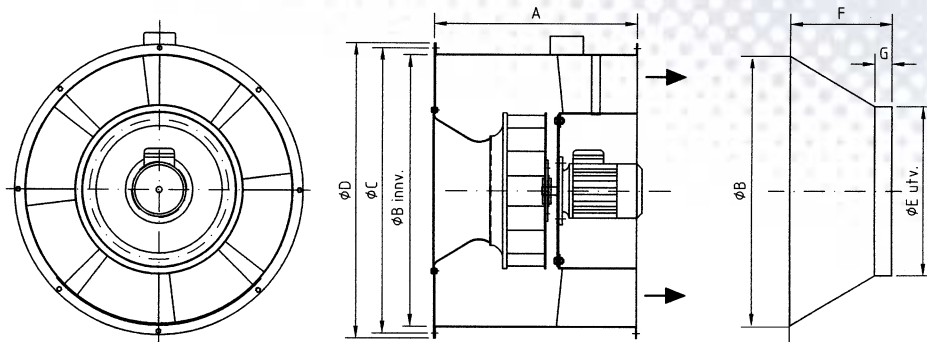

Mounting possibilities

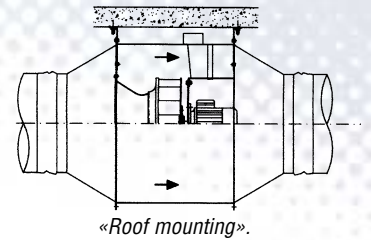

Dimensions

Type	A	B	C	D	E	F	G	Weight kg
400	540	630	665	700	399	250	50	50
500	600	800	835	870	499	300	"	80
560	650	800	835	870	499	300	"	85
630	760	1120	1155	1190	629	450	"	130
800	980	1350	1390	1430	799	500	"	250

We reserve the right to alter dimensions without prior notice. NOTE! Given weights are ex. motor.

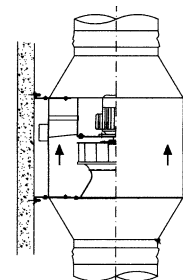
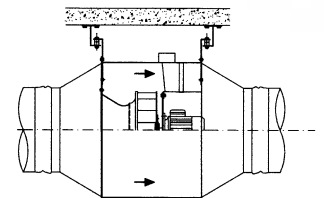

Dimensions for BIL roof mounted fan

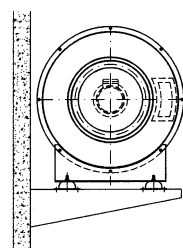
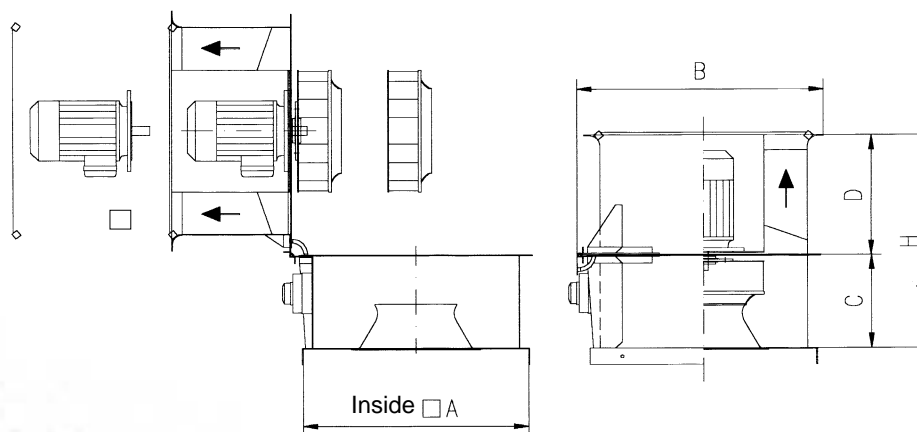

Dimensions

Type	A	B	C	D	H	Weight kg
BIL 400	700	765	290	370	795	60
BIL 500	840	910	350	325	660	90
BIL 560	850	950	395	350	750	110
BIL 630	1195	1260	465	420	885	170
BIL 800	1440	1510	565	535	1100	320

We reserve the right to alter dimensions without prior notice. NOTE! Given weights are ex. motor.

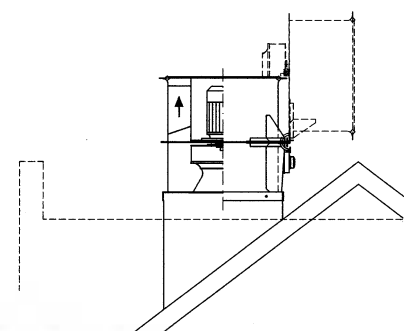

Performance

Performance curves shown, are direct driven fans with 50 Hz motor.

All fans can be frequency controlled. In regulated areas, see Chicago Blower curves for corresponding impeller A and B.

Curve for A impeller

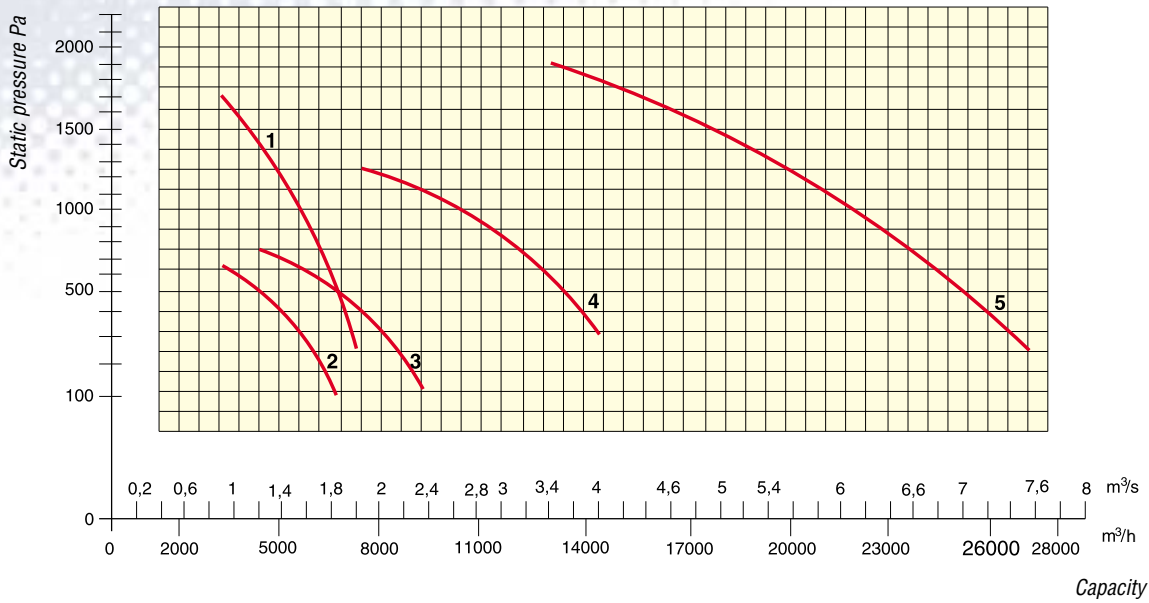

Curve for B impeller

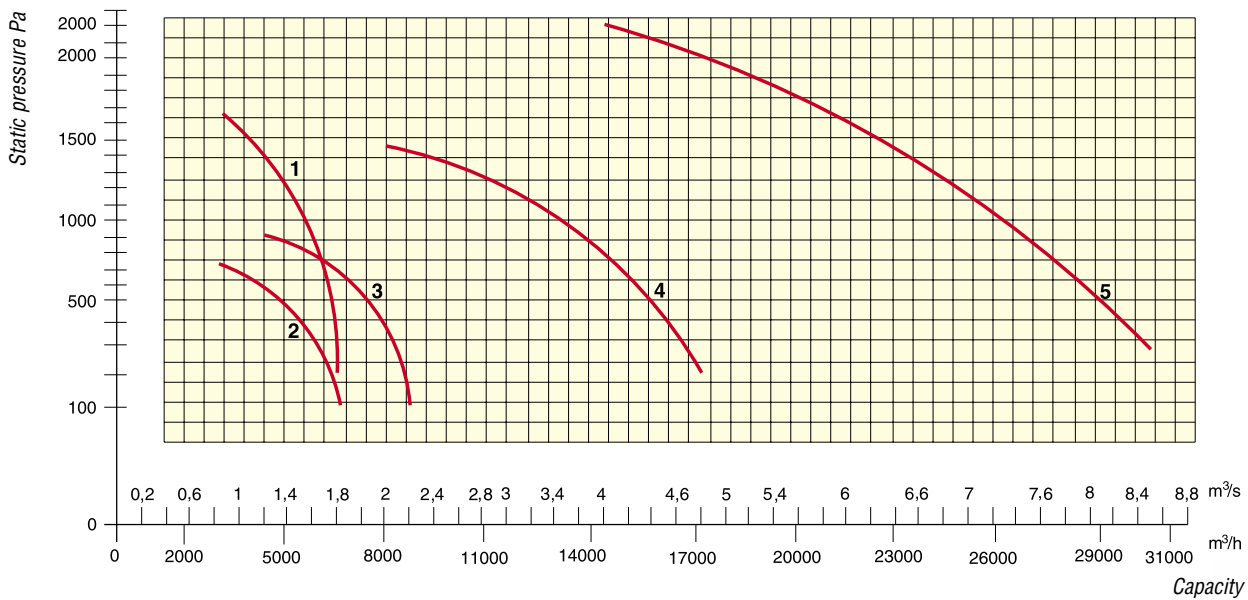

Technical data

Type	Curve	Motor size	CB-impeller
BIL 400	A1	2,2 kW 2880 rpm.	13½ A
BIL 400	B 1	3,0 kW 2880 rpm.	13½ B
BIL 500	A&B 2	1,1 kW 1440 rpm.	16½ A&B
BIL 560	A&B 3	2,2 kW 1440 rpm.	18¼ A&B
BIL 630	A&B 4	4,0 kW 1440 rpm.	22¼ A&B
BIL 800	A 5	7,5 kW 1440 rpm.	27 A
BIL 800	B 5	11,0 kW 1440 rpm.	27 B

